

Hadoop Think Large!



Web Site:

www.soebes.com

Email:

training@soebes.com

Dipl.Ing.(FH) Karl Heinz Marbaise

Agenda

1. Introduction
2. Hadoop Distributed File System (HDFS)
3. Map/Reduce programming paradigm
4. Map/Reduce and HDFS
5. HDFS Installation Requirements + DEMO
6. Real World Example(s)
7. Conclusion

1. Introduction

```
block 0: V----- 0/0          0 1970-01-01 01:00:00 20090619040001--Volume Header--
.
block 1048: -rwxr-xr-x root/root 110912 2005-03-19 20:23:35 ./bin/ash
block 1266: lrwxrwxrwx root/root   0 2006-05-06 15:51:27 ./bin/awk -> gawk
.
block 1523: -rwxr-xr-x root/root 17884 2005-03-19 18:41:22 ./bin/rpm
.
block 5237: -rwxr-xr-x root/root 15428 2005-03-19 21:28:25 ./bin/echo
block 5269: -rwxr-xr-x root/root 235844 2005-03-22 19:58:00 ./bin/gawk
block 5731: -rwxr-xr-x root/root 115424 2005-03-19 21:21:08 ./bin/grep
block 5958: -rwxr-xr-x root/root 51844 2005-03-19 20:15:59 ./bin/gzip
block 6061: -rwxr-xr-x root/root 18000 2005-03-19 21:28:25 ./bin/kill
block 6098: lrwxrwxrwx root/root   0 2006-05-06 15:53:46 ./bin/mail -> /usr/bin/nail
.
block 10480: drwxr-xr-x root/root   0 2005-03-23 22:34:44 ./etc/ppp/ip-up.d/
block 10481: -rw-r--r-- root/root 222 2005-03-19 21:39:38 ./etc/raw
block 10483: -rw-r--r-- root/root 1615 2005-03-19 18:29:54 ./etc/rpc
block 10488: drwxr-xr-x root/root   0 2006-06-10 12:25:23 ./etc/ssh/
block 10489: -rw-r--r-- root/root 2384 2005-03-22 19:53:04 ./etc/ssh/ssh_config
block 10495: -rw-r----- root/root 3459 2006-05-07 12:30:13 ./etc/ssh/sshd_config
block 10503: -rw----- root/root 528 2006-05-06 16:02:58 ./etc/ssh/ssh_host_key
block 10506: -rw-r--r-- root/root 603 2006-05-06 16:03:01 ./etc/ssh/ssh_host_dsa_key.pub
block 10509: -rw-r--r-- root/root 223 2006-05-06 16:03:01 ./etc/ssh/ssh_host_rsa_key.pub
block 10511: -rw----- root/root 111892 2005-03-22 19:53:04 ./etc/ssh/moduli
block 10731: -rw-r--r-- root/root 332 2006-05-06 16:02:58 ./etc/ssh/ssh_host_key.pub
block 10733: -rw----- root/root 668 2006-05-06 16:03:01 ./etc/ssh/ssh_host_dsa_key
block 10736: -rw----- root/root 883 2006-05-06 16:03:01 ./etc/ssh/ssh_host_rsa_key
block 10739: drwxr-xr-x root/root   0 2007-01-20 18:13:19 ./etc/ssl/
```

1. Introduction

Java implementation

```
public void process(String strLine) {
    String[] columns = strLine.split("[ ]+");
    if (strLine.startsWith("tar: /dev/nst0")) {
        getContext().getCounter(ContentType.EMPTY).increment(1);
        return;
    }
    if (columns[2].startsWith("-")) {
        long sizeInBytes = Long.parseLong(columns[4]);
        getContext().getCounter(ContentType.BYTES).increment(sizeInBytes);
        getContext().getCounter(ContentType.FILES).increment(1);
    }
    if (columns[2].startsWith("d")) {
        context.getCounter(ContentType.DIRECTORIES).increment(1);
    }
    if (columns[2].startsWith("l")) {
        getContext().getCounter(ContentType.LINKS).increment(1);
    }
    if (columns[2].startsWith("V")) {
        getContext().getCounter(ContentType.VOLUMNHEADER).increment(1);
    }
}
```

<https://github.com/khmarbaise/hadoop-compare>

1. Introduction

Java implementation II

```
public void read(File logFile) {
    BufferedReader in = null;
    try {
        in = new BufferedReader(new FileReader(logFile));
        String str;
        while ((str = in.readLine()) != null) {
            process(str);
        }
    } catch (IOException e) {
        System.err.println("Failure during read:" + e.getMessage());
    } finally {
        try {
            in.close();
        } catch (IOException e) {
            System.err.println("Failure during close:" + e.getMessage());
        }
    }
}
```

<https://github.com/khmarbaise/hadoop-compare>

1. Introduction

Java implementation III

```
public static void main(String[] args) {
    TapeLogReader rlr = new TapeLogReader();
    Date started = new Date();
    System.out.println("Started at: " + started);
    rlr.read(new File(args[0]));
    Date ended = new Date();
    System.out.println("Stopped at: " + ended);
    System.out.println("Runtime: "
        + ((ended.getTime() - started.getTime()) / 1000.0)
        + " seconds");

    for (ContentType item : ContentType.values()) {
        Counter counter = rlr.getContext().getCounter(item);
        System.out.println("Counter: "
            + item.name() + " value:" + counter.getValue());
    }
}
```

<https://github.com/khmarbaise/hadoop-compare>

1. Introduction

Test on Files

(18.08 GiB File)

```
hudson@build:~/hadoop-compare-0.0.1-SNAPSHOT> bin/tlr ../logs/result.log
```

```
Started at: Sat Feb 12 12:16:32 CET 2011
```

```
Stopped at: Sat Feb 12 12:26:09 CET 2011
```

```
Runtime: 577.15 seconds
```

```
Counter: FILES value:98129391
```

```
Counter: DIRECTORIES value:24770057
```

```
Counter: LINKS value:236933
```

```
Counter: VOLUMNHEADER value:305
```

```
Counter: EMPTY value:209
```

```
Counter: BYTES value:24594160609582
```

(21.91 GiB File)

```
hudson@build:~/hadoop-compare-0.0.1-SNAPSHOT> bin/tlr ../logs/r.log
```

```
Started at: Sat Feb 12 13:28:32 CET 2011
```

```
Stopped at: Sat Feb 12 13:39:29 CET 2011
```

```
Runtime: 656.252 seconds
```

```
Counter: FILES value:118228777
```

```
Counter: DIRECTORIES value:30492033
```

```
Counter: LINKS value:284020
```

```
Counter: VOLUMNHEADER value:364
```

```
Counter: EMPTY value:311
```

```
Counter: BYTES value:29684714834632
```

<https://github.com/khmarbaise/hadoop-compare>

1. Introduction

- What about if the file(s) become larger?
- Let us assume the file will get 200 **GiB*** or 2 **TiB** or even larger.
- Rule of thumb calculation:

Size	Unit	Minutes	Hours	Days
20	GiB	10		
200	GiB	100	1.6	
2	TiB	1000	16.6	0.69
20	TiB	10000	166	6.94
200	TiB	100000	1666	69.4

*1999 IEC 60027-2 Amendment 2

1. Introduction

- What can we do to reduce the amount of time to analyze files? One solution might be parallelization:
- Prerequisites:
 - Split the file(s) into chunks.
 - Synchronization between threads.
 - Limit the number of parallel running threads.
 - Handling of failures.
 - Etc.

1. Introduction

- Limitations:
 - Only on a single machine.
 - Complex implementation and furthermore very complex tests.
- Open Questions:
 - What about failure scenarios in particular hardware failures ?
 - Reliability?

1. Introduction

- Solution overview:

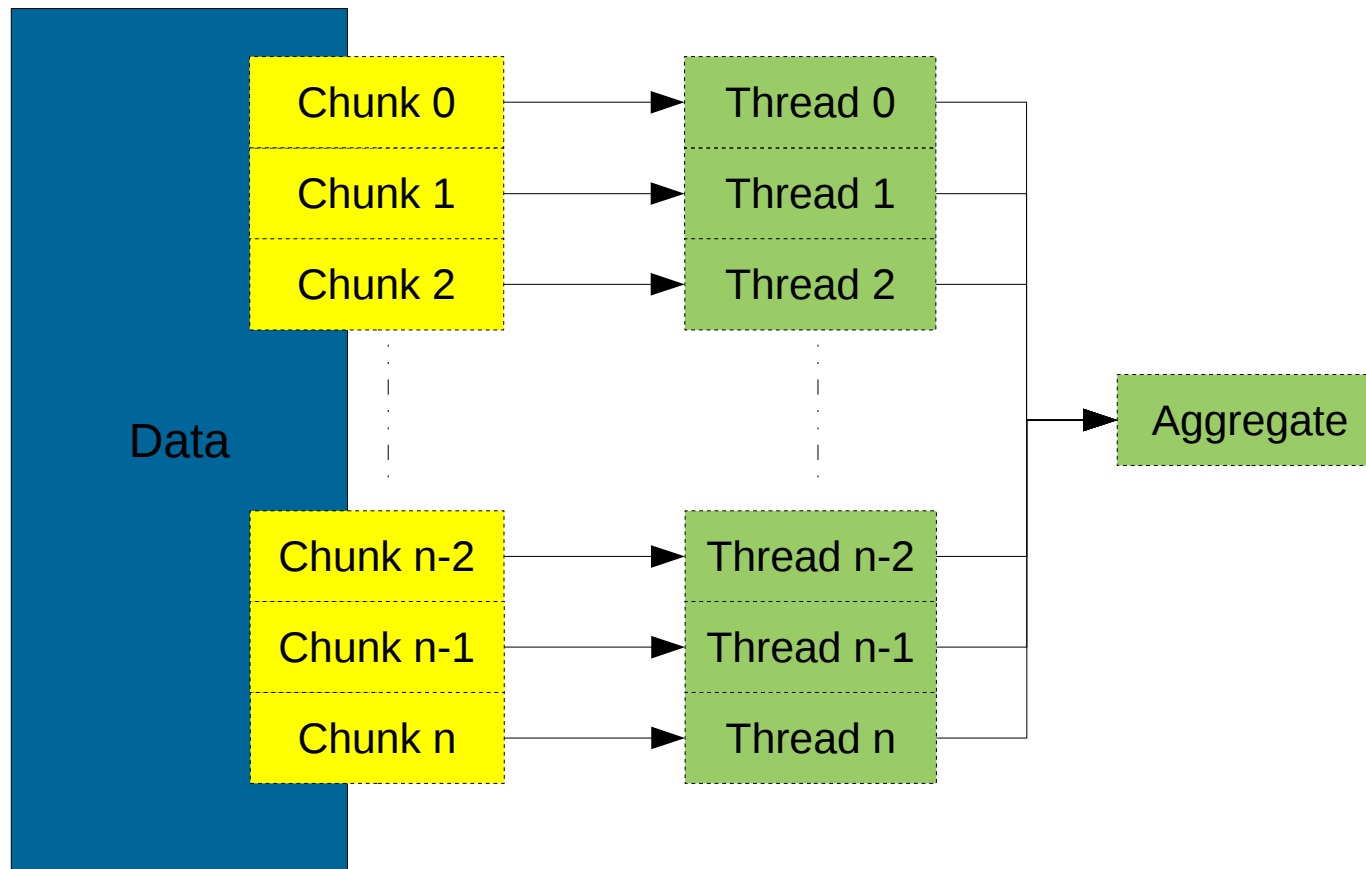

1. Introduction

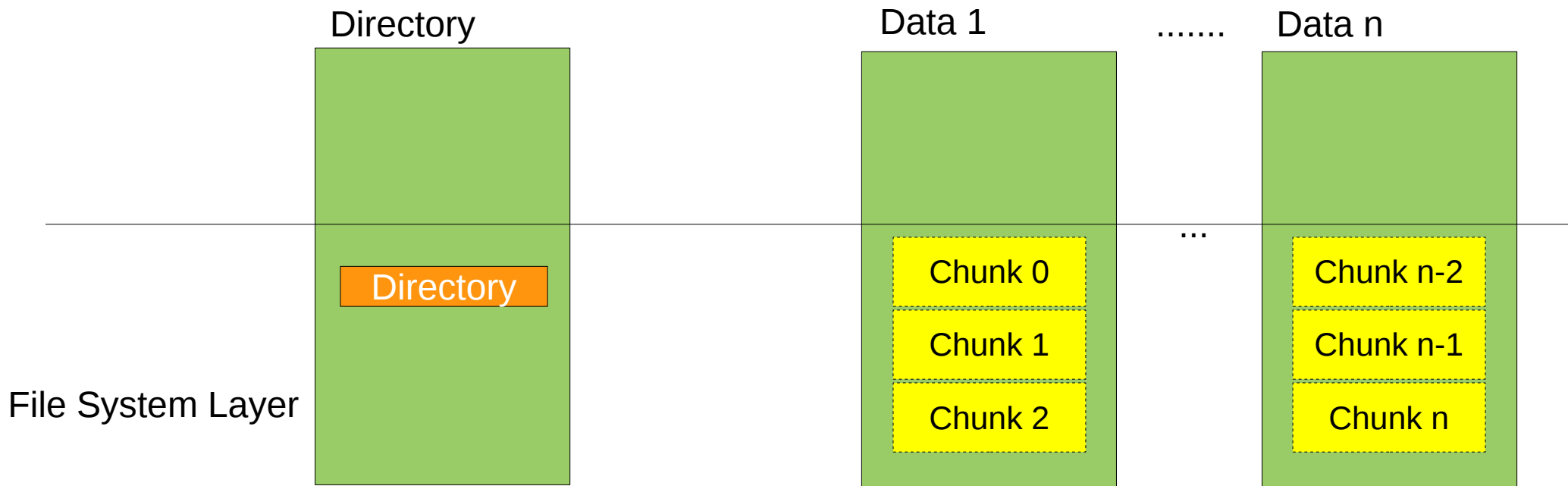

2. Hadoop Distributes File System Architecture

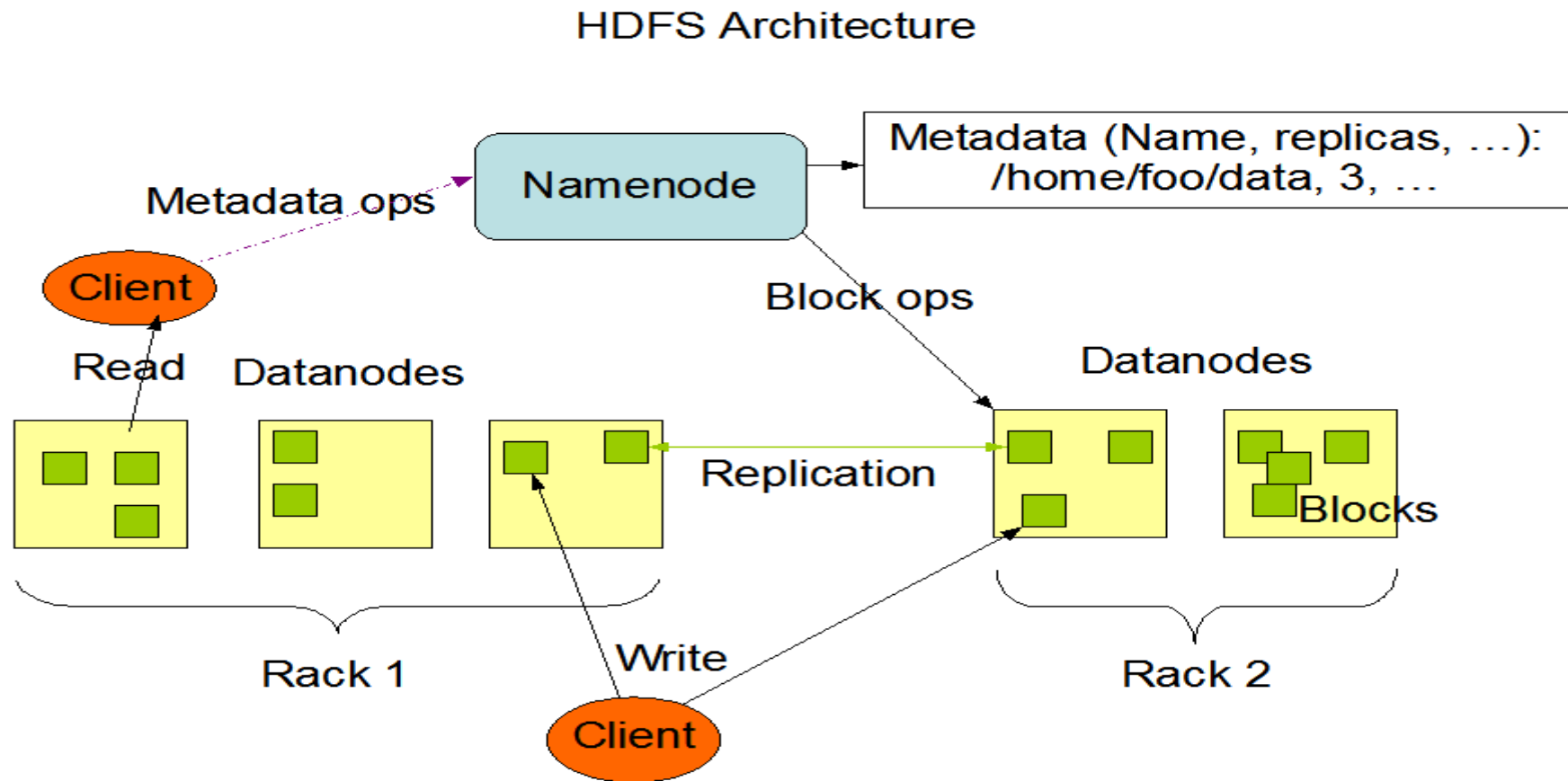

http://hadoop.apache.org/hdfs/docs/current/hdfs_design.html

2. Hadoop Distributes File System Architecture

- Replication of individual files on different data nodes.
- The default replication factor is 3.
- Failures of machines
 - Hardware is not reliable.
- Activation of machines
 - Enhancement of the cluster.
- Deactivation of machines
 - Removing machines from your cluster.

2. Hadoop Distributes File System Architecture

- Name Node
 - Operations are written to logs, makes restart possible
 - The file system is in read only mode during a restart.
 - A secondary Name-Node periodically should read these logs, to speed up availability for restart.
 - A restart of the whole cluster is needed if the secondary Name-Node takes over (host names have changed).
 - Single point of failure and restart can take a long time (may be hours depending on the size of data stored in HDFS).

2. Hadoop Distributes File System Architecture

- Data Node
 - No identity.
 - Share nothing paradigm.
 - Commodity hardware.

2. Hadoop Distributes File System Architecture

- Now we have a file system which can store files distributed over different machines.
- This means you can have files which are larger than the storage in a single machine.
- Pluggable files system
- Access through API layer.
 - Default block size 64 MiB

2. Hadoop Distributed File System Architecture File Write

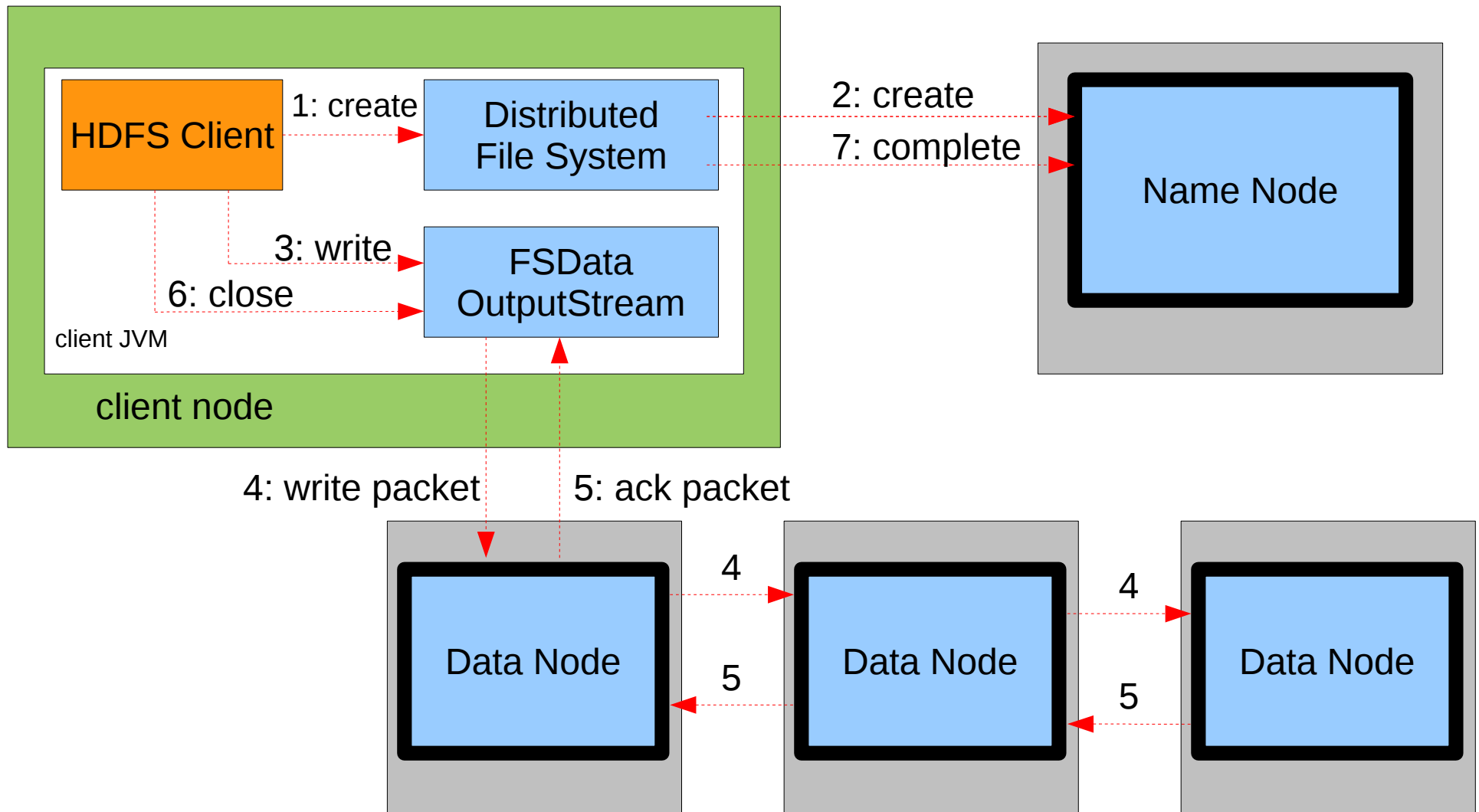

2. Hadoop Distributed File System Architecture File Read

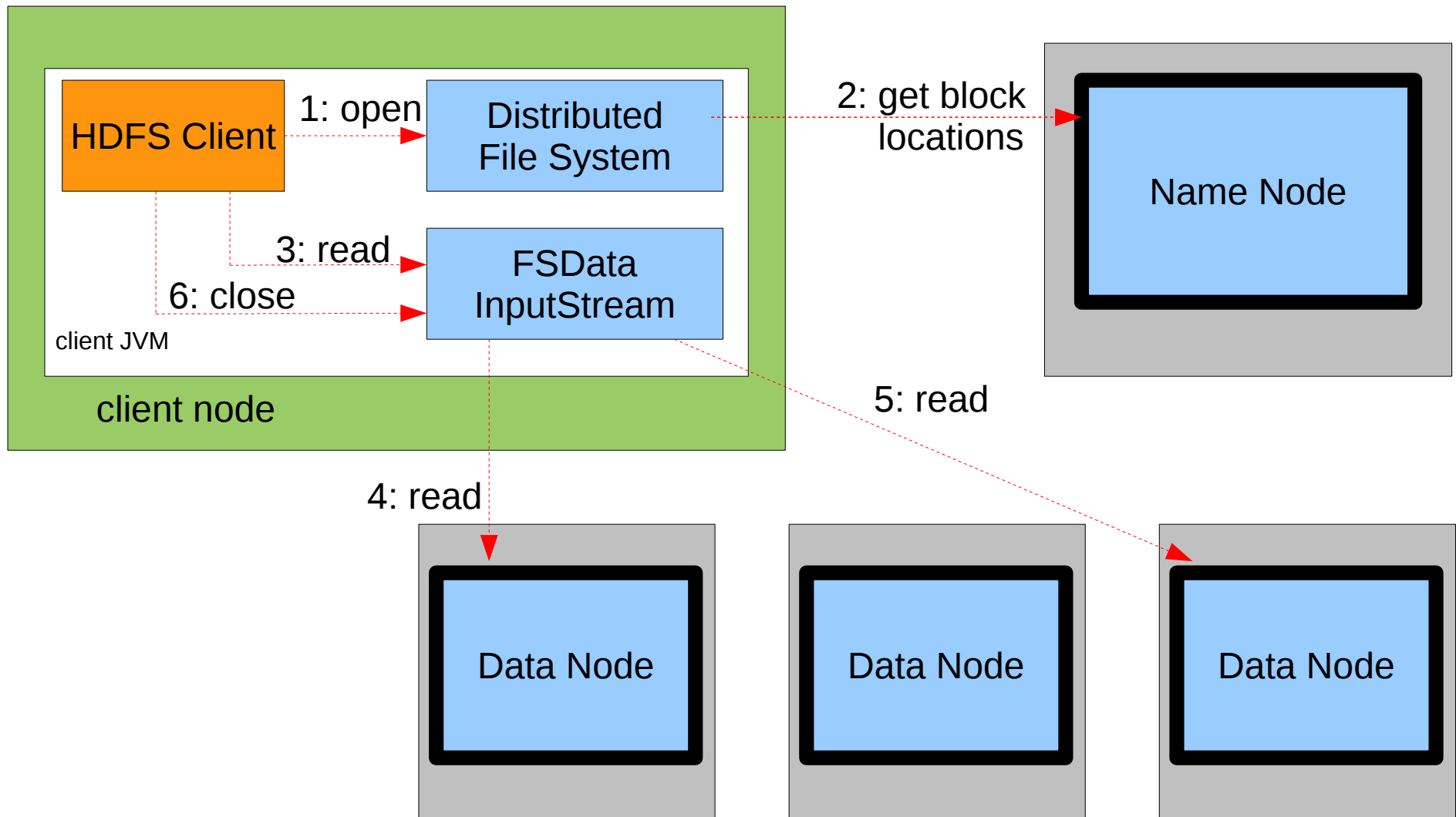

2. Hadoop Distributed File System Architecture

- What about the different cores of the Data Nodes?

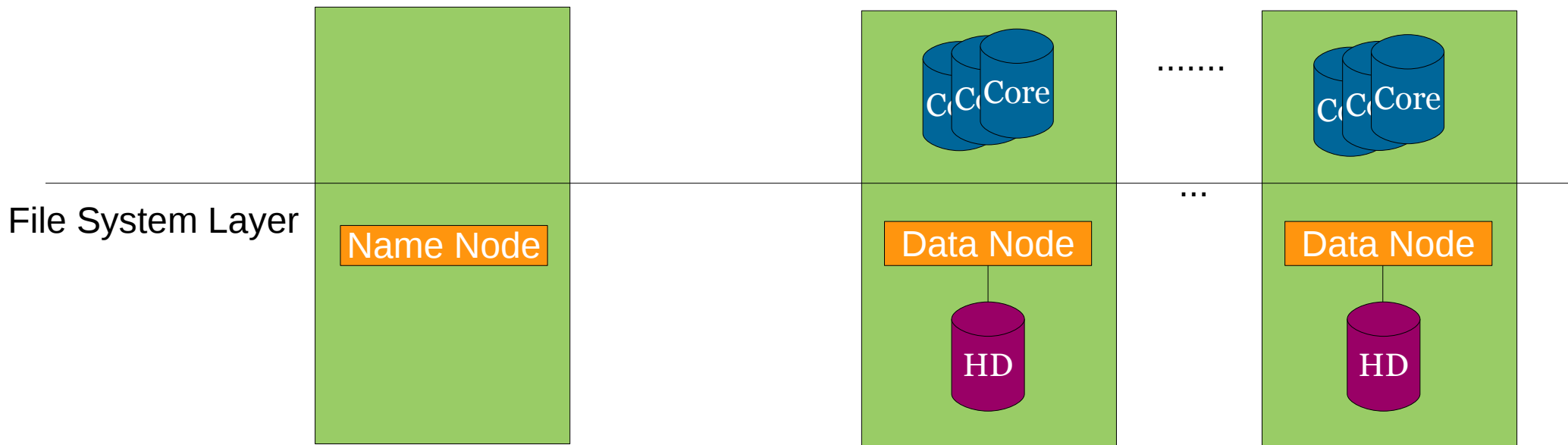

3. Map/Reduce Mapper Theory

- The first phase of a Map/Reduce program is called the Map-Phase. A list of data elements are provided, one at a time, to a function called the Mapper, which transforms each element individually to an output data element.

3. Map/Reduce Mapper Theory

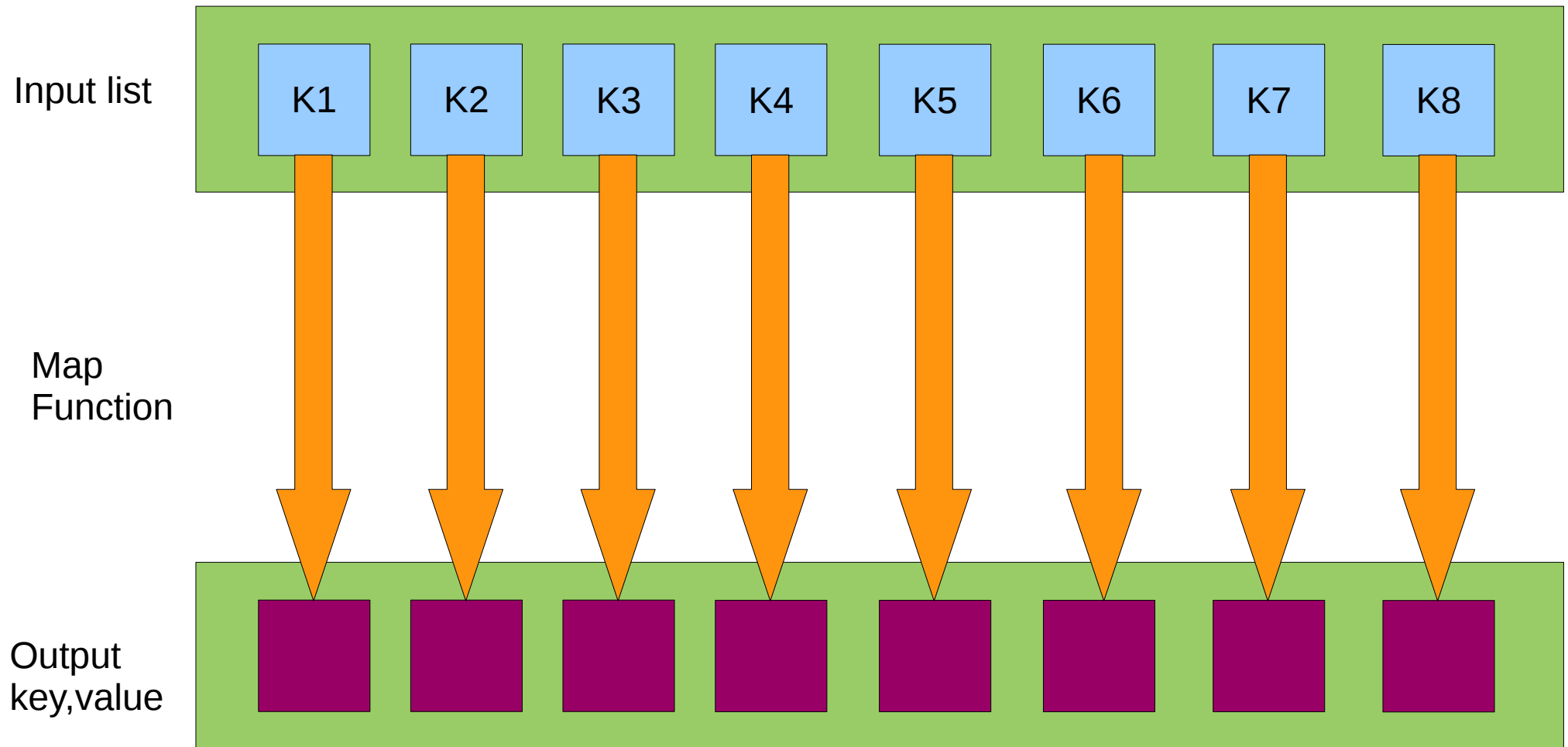

3. Map/Reduce Mapper Theory

- A typical example of the map function:

```
mapper (filename, file-contents):  
  for each word in file-contents:  
    emit (word, 1)
```

3. Map/Reduce Mapper Practice

- The Mapper of Hadoop:

```
public interface Mapper<K1, V1, K2, V2> extends  
    JobConfigurable, Closeable {  
  
    void map(  
        K1 key, V1 value,  
        OutputCollector<K2, V2> output,  
        Reporter reporter  
    ) throws IOException;  
}
```

Example for Hadoop 0.20.0 API

3. Map/Reduce Mapper Practice

- The Mapper of Hadoop:

```
public class Mapper<KEYIN, VALUEIN, KEYOUT, VALUEOUT> {  
  
    protected void map(KEYIN key, VALUEIN value, Context context)  
        throws IOException, InterruptedException {  
  
        context.write((KEYOUT) key, (VALUEOUT) value);  
  
    }  
}
```

Example for Hadoop 0.21.0 API

3. Map/Reduce Mapper Practice

- Let's start with an example in Java Code:

```
public class WordCountMap implements Mapper<LongWritable, Text, Text, IntWritable> {  
  
    private final static IntWritable one = new IntWritable(1);  
    private Text word = new Text();  
  
    public void map(  
        LongWritable key, Text value, OutputCollector<Text, IntWritable> output, Reporter reporter  
    ) throws IOException {  
  
        String line = value.toString();  
        StringTokenizer tokenizer = new StringTokenizer(line);  
        while (tokenizer.hasMoreTokens()) {  
            word.set(tokenizer.nextToken());  
            output.collect(word, one);  
        }  
    }  
}
```

Example for Hadoop 0.20.0 API

3. Map/Reduce Mapper Practice

- Let's start with an example in Java Code:

```
public class WordCountMapper extends
    Mapper<LongWritable, Text, Text, LongWritable> {

    private LongWritable one = new LongWritable(1);
    private Text word = new Text();

    public void map(LongWritable key, Text value, Context context)
        throws InterruptedException, IOException {

        StringTokenizer token = new
            StringTokenizer(value.toString(), ".,-! \\t\\n\\r\\f");
        while (token.hasMoreTokens()) {
            word.set(token.nextToken());
            context.write(word, one);
        }
    }
}
```

Example for Hadoop 0.21.0 API

3. Map/Reduce Mapper Practice

- Output of the mapper:

```
this, 1  
there, 1  
goto, 1  
help, 1  
test, 1  
test, 1  
there, 1  
those, 1  
there, 1  
this, 1  
...
```

3. Map/Reduce Reducer Theory

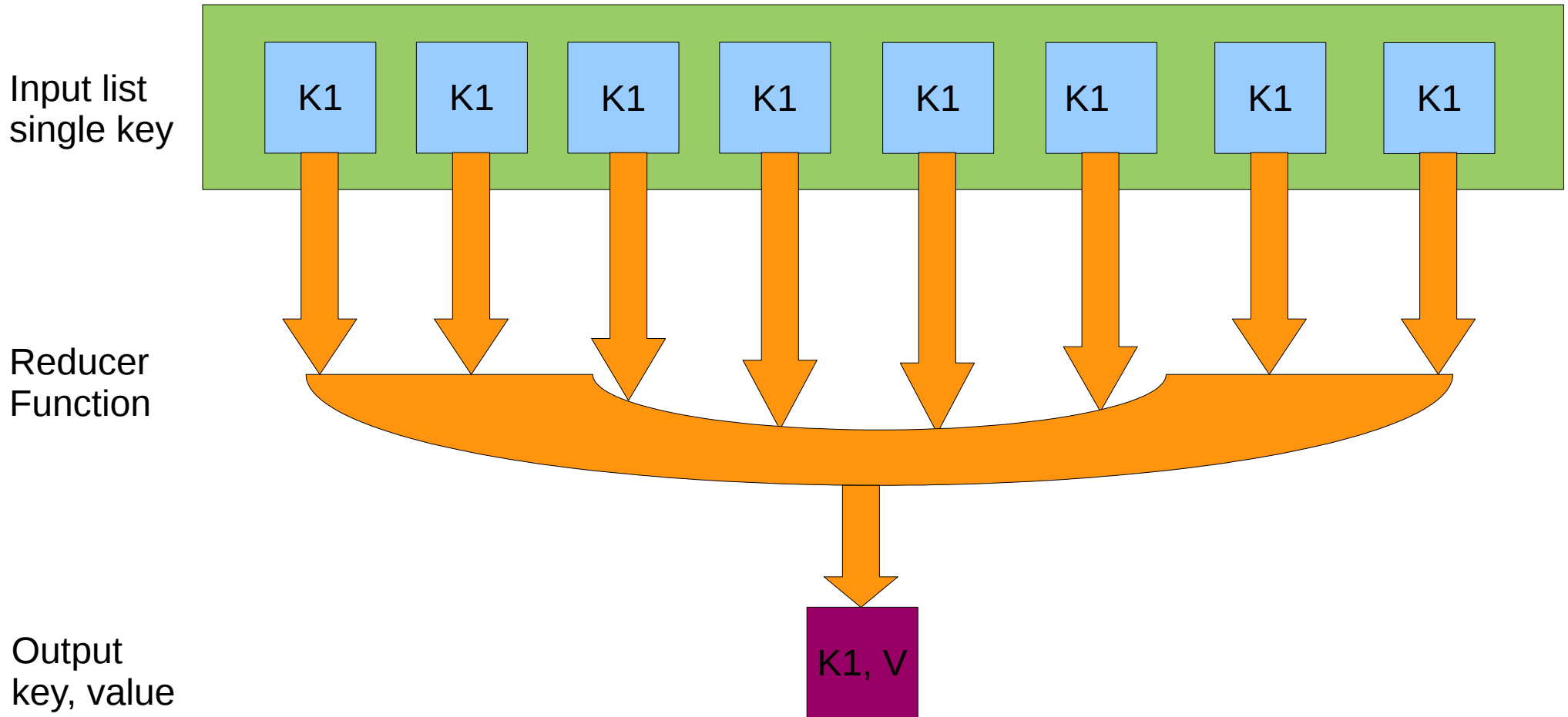

3. Map/Reduce Reducer Theory

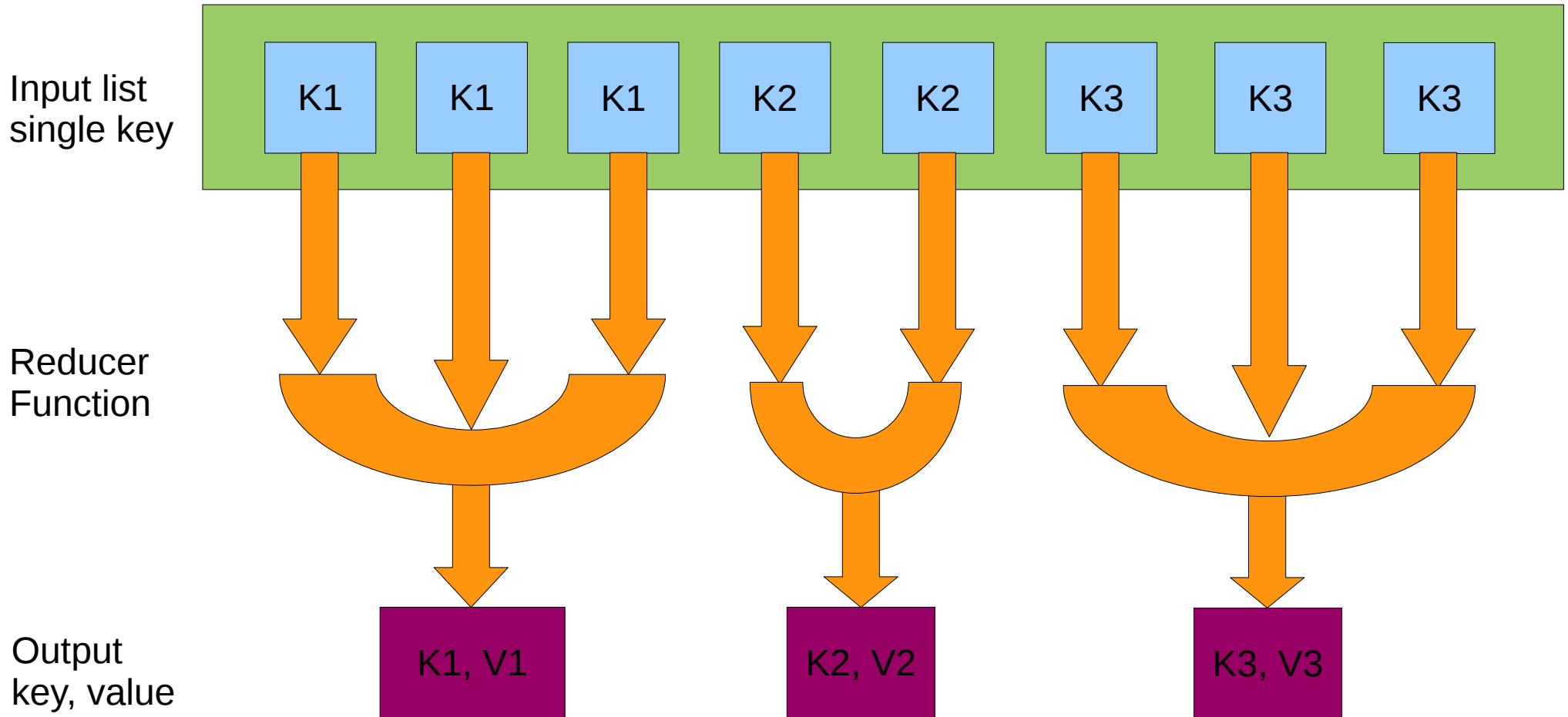

3. Map/Reduce

Reducer Theory

- A typical example of the reducer function:

```
reducer (word, values):
```

```
    sum = 0
```

```
    for each value in values:
```

```
        sum = sum + value
```

```
    emit (word, sum)
```

3. Map/Reduce Reducer Practice

```
public static class WordCountReduce extends MapReduceBase
implements Reducer<Text, LongWritable, Text, LongWritable> {

    public void reduce(
        Text key, Iterator<LongWritable> values,
        OutputCollector<Text, LongWritable> output,
        Reporter reporter) throws IOException {

        int sum = 0;
        while (values.hasNext()) {
            sum += values.next().get();
        }
        output.collect(key, new LongWritable(sum));
    }
}
```

Example for Hadoop 0.20.0 API

3. Map/Reduce Reducer Practice

```
public class WordCountReducer extends
    Reducer<Text, LongWritable, Text, LongWritable> {

    @Override
    public void reduce(Text key, Iterable<LongWritable> values,
        Context context)
        throws InterruptedException, IOException {

        long summ = 0;
        for (LongWritable value : values) {
            summ += value.get();
        }
        context.write(key, new LongWritable(summ));
    }
}
```

Example for Hadoop 0.21.0 API

3. Map/Reduce

Reducer Practice

- Output of the mapper:

```
this, 1  
there, 1  
goto, 1  
help, 1  
test, 1  
test, 1  
there, 1  
those, 1  
there, 1  
this, 1  
...
```

- Output of the reducer:

```
this, 2  
there, 3  
goto, 1  
help, 1  
test, 2  
...
```

4. Map/Reduce and HDFS

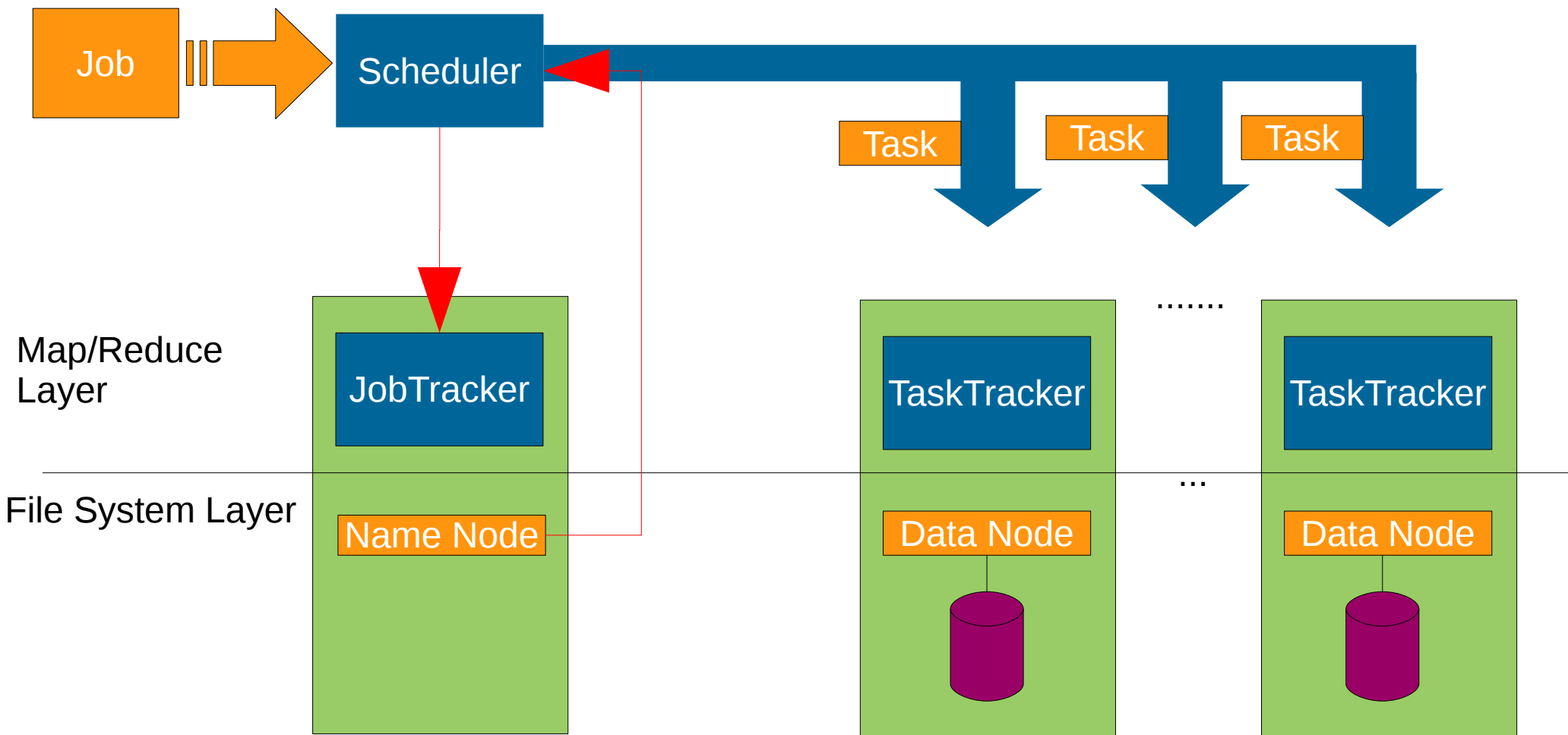

4. Map/Reduce and HDFS

```
public class WordCountRunner extends Configured implements Tool {
    @Override
    public int run(String[] args) throws Exception {
        Configuration conf = new Configuration();
        String[] otherArgs = new GenericOptionsParser(conf, args).getRemainingArgs();
        ...
        Job job = new Job(conf, "WordCount");
        job.setJarByClass(WordCountRunner.class);
        job.setMapperClass(WordCountMapper.class);
        job.setReducerClass(WordCountReducer.class);
        job.setOutputKeyClass(Text.class);
        job.setOutputValueClass(LongWritable.class);
        job.setMapOutputKeyClass(Text.class);
        job.setMapOutputValueClass(LongWritable.class);
        FileInputFormat.addInputPath(job, new Path(otherArgs[0]));
        FileOutputFormat.setOutputPath(job, new Path(otherArgs[1]));
        System.exit(job.waitForCompletion(true) ? 0 : 1);
        return 0;
    }
    public static void main(String[] args) throws Exception {
        int res = ToolRunner.run(new Configuration(), new WordCountRunner(), args);
        System.exit(res);
    }
}
```

4. Map/Reduce and HDFS

Start a Job

- Start a Map/Reduce job:

```
bin/hadoop jar \  
  /usr/km/wordcount.jar \  
  org.myorg.WordCount \  
  /usr/joe/wordcount/input \  
  /usr/joe/wordcount/output
```

5. Hadoop Distributes File System Installation Requirements

- GNU/Linux is supported as a development and production platform. Hadoop has been demonstrated on GNU/Linux clusters with 2000 nodes.
- Win32 is supported as a development platform. Distributed operation has not been well tested on Win32, so it is **not supported as a production platform**.

5. Hadoop Distributes File System Installation Requirements

- Java™ 1.6.x, preferably from Sun, must be installed.
- ssh must be installed and sshd must be running to use the Hadoop scripts that manage remote Hadoop daemons.
- **ssh localhost** via public key must be working.
- On the different machines a user called hadoop (obviously ;-)) should be created and accessible via ssh from the name node.

5. Map/Reduce and HDFS Demo

DEMO

6. Real World: Facebook

- 21 PiB (30 PiB Nov. 2010)
- 2000 machines (3000 in Nov. 2010)
- 12 TiB per machine (a few have 24 TiB each)
- 1200 machines with 8 cores each
- 800 machines with 16 cores each
- 32 GiB RAM per machine

<http://hadoopblog.blogspot.com/2010/05/facebook-has-worlds-largest-hadoop.html>

http://developer.yahoo.com/blogs/hadoop/posts/2010/05/scalability_of_the_hadoop_dist/

6. Real World: Facebook

- 12 TiB of compressed data added per day
- 800 TiB of compressed data scanned per day (1 PiB per day Nov. 2010)
- 25,000 map-reduce jobs per day
- 65 millions files in HDFS
- 30,000 simultaneous clients to the HDFS NameNode

<http://hadoopblog.blogspot.com/2010/05/facebook-has-worlds-largest-hadoop.html>

http://developer.yahoo.com/blogs/hadoop/posts/2010/05/scalability_of_the_hadoop_dist/

6. Real World

- Take a look here:
 - <http://wiki.apache.org/hadoop/PoweredBy>
 - Hadoop World NYC

7. Conclusion

- HDFS is a file system write-once read multiple times (appending is also possible 0.21.0 API).
- Hadoop is not a replacement for RDBMS.
- It is not simple to write Map/Reduce jobs
 - May be take a look at Hive (DWH SQL), HTable, Pig etc.
- If a node fails not the whole cluster will fail only the throughput will reduce by a percentage rate.

7. Conclusion

- What is the size to start with?
 - You can start with 3(Data nodes)+1(Name Node) Nodes and continue to enhanced the size based on your requirements.
 - Or
 - Just rent a Hadoop cluster => Amazon....

Appendix

References

- Hadoop Homepage
 - <http://hadoop.apache.org>
- HDFS Homepage
 - <http://hadoop.apache.org/hdfs>
- Map/Reduce
 - <http://hadoop.apache.org/mapreduce>
- Google Map/Reduce
 - <http://labs.google.com/papers/mapreduce.html>

Appendix

References

- Hive
 - <http://hive.apache.org/>
- Pig
 - <http://pig.apache.org/>
- HBase
 - <http://hbase.apache.org/>
- Cloudera (Map/Reduce, Hadoop etc.)
 - <http://www.cloudera.com/resources/?type=Training>

Appendix

References

- Yahoo Developer Resources
 - <http://developer.yahoo.com/hadoop/tutorial/index.html>
- Yahoo M/R
 - <http://developer.yahoo.com/hadoop/tutorial/module4.htm>
- Videos about M/R
 - <http://vimeo.com/3584536>